

PA960-44(Z) Data Sheet

44 pin PLCC socket/40 pin DIP 0.6" plug

Supported Device/Footprints

This adapter follows Intel's specification to program 44 pin PLCC 27960CX/KX EPROMs on 40 pin DIP programmers.

Mfgr	Device		Device	Footprint Plug
	Device	Package		
Intel	27960	PLCC	27960	40 Pin DIP

Adapter Parts & Part Numbers

The following chart shows the various socket and board part numbers that make up these adapters.

Adapter	Test Socket	Top Board	Bottom Board
PA960-44	44-106 or 44-306	44PL2 -1 or 44PL2-3	27960
PA960-44Z	44-400	44PL2-Z	27960

Adapter Dimensions

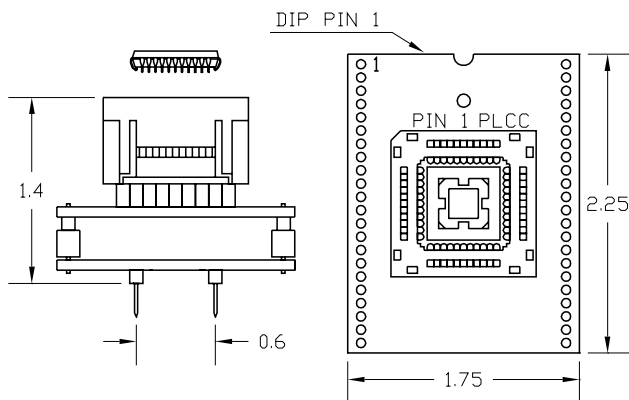

Press rim to open socket, Press device to close

PA960-44

Adapter Construction

The adapter is made up of 3 sub-assemblies. They assemble via connectors making the adapter modular. This way the sub-assemblies can be replaced when they wear out.

When disassembling the adapter take care not to bend the pins. When reassembling the adapter note the pin 1 indicators to align the parts correctly.

Test Socket

PLCC Auto-Eject test socket:

Yamaichi Part #: IC120-0444-106

LSC Part #: 44-106

Yamaichi Part #: IC120-0444-306

LSC Part #: 44-306

ZIF Lidded socket:

Yamaichi Part #: IC51-0444-400

LSC Part #: 44-400

44PL2-1, -3, -Z

Accepts the test socket and connects to the bottom board.

27960

Performs the wiring shown in the Adapter Wiring section.

Adapter Wiring

The following chart shows the connections from the PLCC device to the adapter's DIP plug.

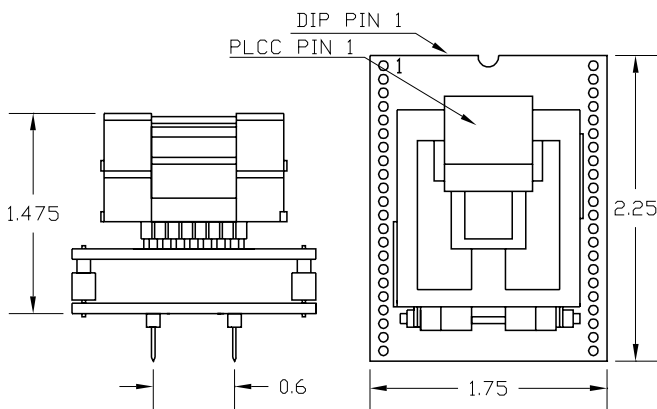

PA960-44Z

DEVICE	SIGNAL	PLUG	PLUG	SIGNAL	DEVICE
1	BLAST	20	40	Vcc	44
2	Vpp	1	39	PGM	43
3	CS	2	10	ADS	42
4	CLK	8	6	A18	41
5	GND	11	7	A17	40
6	07	12	38	A16	39
7	06	13	37	A15	38
8	GND	11	36	A14	37
9	Vcc	40	35	A13	36
10	05	14	34	A12	35
11	04	15	33	A11	34
12	GND	11	32	A10	33
13	03	16	31	A9	32
14	02	17	29	A8	31
15	GND	30	28	A7	30
16	Vcc	40	27	A6	29
17	01	18	26	A5	28
18	00	19	25	A4	27
19	GND	30	24	A3	26
20	Vcc	40	23	A2	25
21	GND	30	22	A1	24
22	RST	9	21	A0	23



Adapters-Plus Inc.

P.O. BOX 900

Tracy, Ca 95378

ph.209-839-0200

fax.209-839-0235

email: sales@adapt-plus.com

www.adapt-plus.com